



A&A Channel Floor Drain Vinyl Liner Model Installation Instructions

Important Note to the Plumber: Pressure testing must be performed with the Channel Drain glued in place. There is a test plug (see Figure 2) already installed and a plastic construction shield secured by screws and taped in place to prevent debris and construction material from entering the Channel Drain during construction. (Because the Channel Drain is an un-blockable fitting, no other suction fitting is necessary.) The maximum flow rate of the Channel Drain, certified by the NSF, is 227 GPM (1.1 ft/sec) for Dual-suction & 196 GPM (1.0 ft/sec) for Single Suction. **Maximum flow rate is not to be exceeded! NEVER INSTALL THE CHANNEL DRAIN IN A SEAT OR A BACKREST AREA!**

1. It is important that the Channel Drain is installed directly in the middle of the deepest point in the pool and that it is set at the proper height. The top of the Channel Drain will set the floor height and the depth of the pool.
2. In order to ensure that the Channel Drain is set at the proper height, a string line must be run in the hopper of the pool at the correct floor height. This procedure is identical to the current method of setting standard drain(s).
3. After the string lines have been set at the proper height, place the Channel Drain in its exact location.
4. Over excavate an area **around and under** the Channel Drain location a minimum of 6 inches around all sides and deep enough to allow for the stub plumbing out of the bottom of the Channel drain.
5. Pre-plumb you suction lines to the Channel Drain, using a long enough pipe stub to clear the drain area for concrete to be set around the Channel Drain.
6. It is recommended that the Channel Drain be plumbed with 3" PVC pipe. Adjust the stub so that the top of the Channel Drain is at the same height as the string line which represents the finished floor level. Certified flow rates are based on 3" plumbing only.
7. Make sure the Channel Drain is leveled and plumb in all directions (see Figure 1).

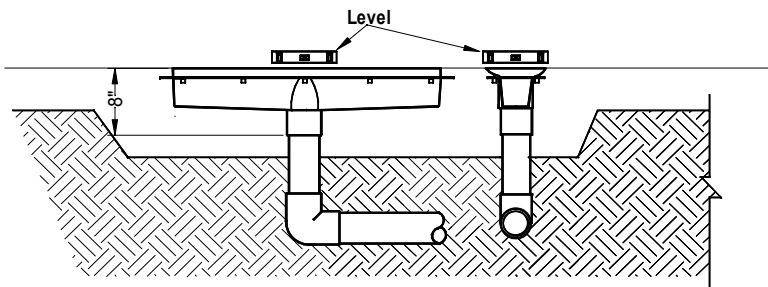

Figure 1

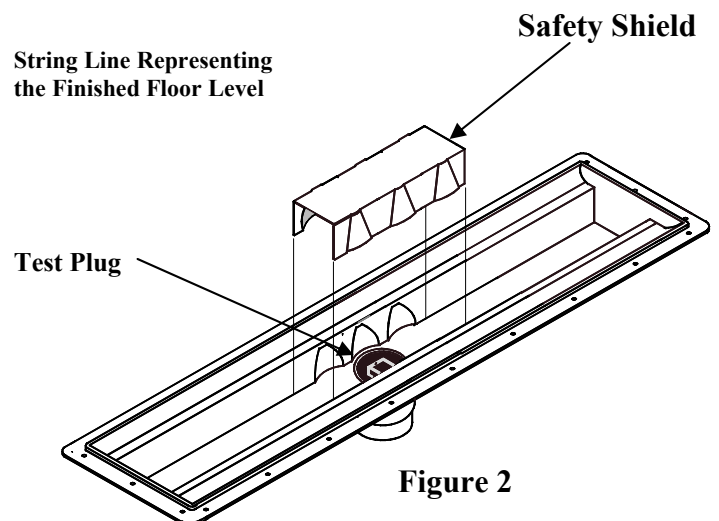

Figure 2

8. Extend the plumbing from the Channel Drain to the pump or pumps. **Note** that the Channel Drain may be configured to accommodate more than one pump by ordering from A&A Manufacturing an additional suction port to the bottom of the unit (see Figure 3).
9. Pressure test the plumbing run(s) to the Channel Drain.
10. Pack a concrete mixture under and around the Channel Drain. Make sure enough concrete is used to **FIRMLY SECURE** the Channel Drain from any movement during all of the remaining steps of construction.

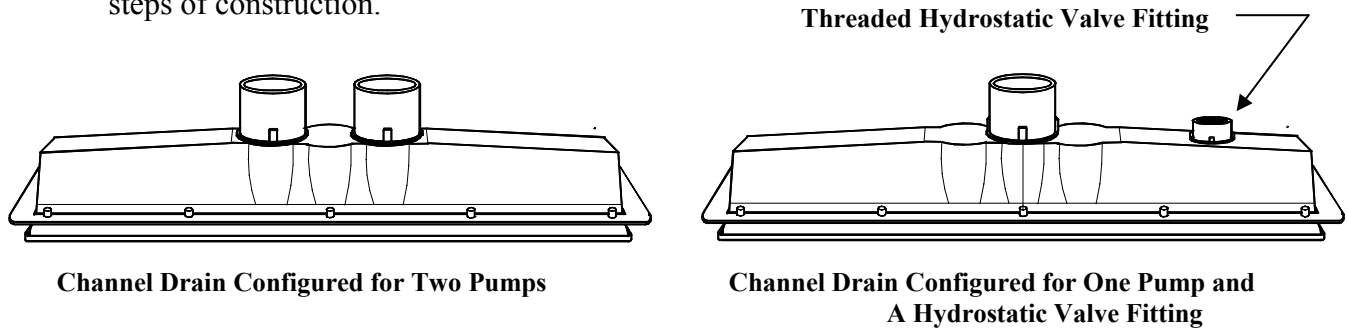

Figure 3

Applying Finished Floor Material

1. At the appropriate time in the construction phase, apply the floor material around the Channel Drain. Trowel the floor finish up to and level with the lip of the face plate bottom.
2. Once the pool floor has been prepared for the liner, remove the tape and screws from the plastic Construction Shield.
3. Remove the test plug(s) from the bottom port(s).
4. Install the Safety Shield(s) with the supplied glue packet (see Figure 2 and 4).
5. Install the supplied gasket, this can be spot glued as required. Note that the gasket has tabs that can be popped into the appropriate holes in the plate tray of the Channel Drain (see Figure 5).

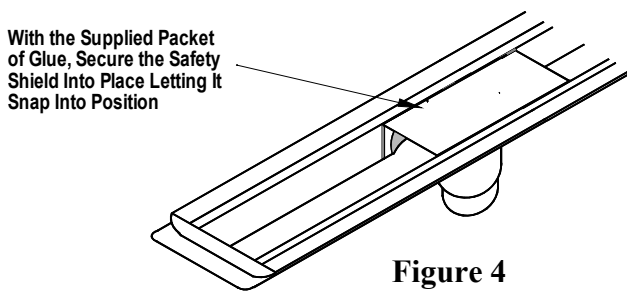

Figure 4

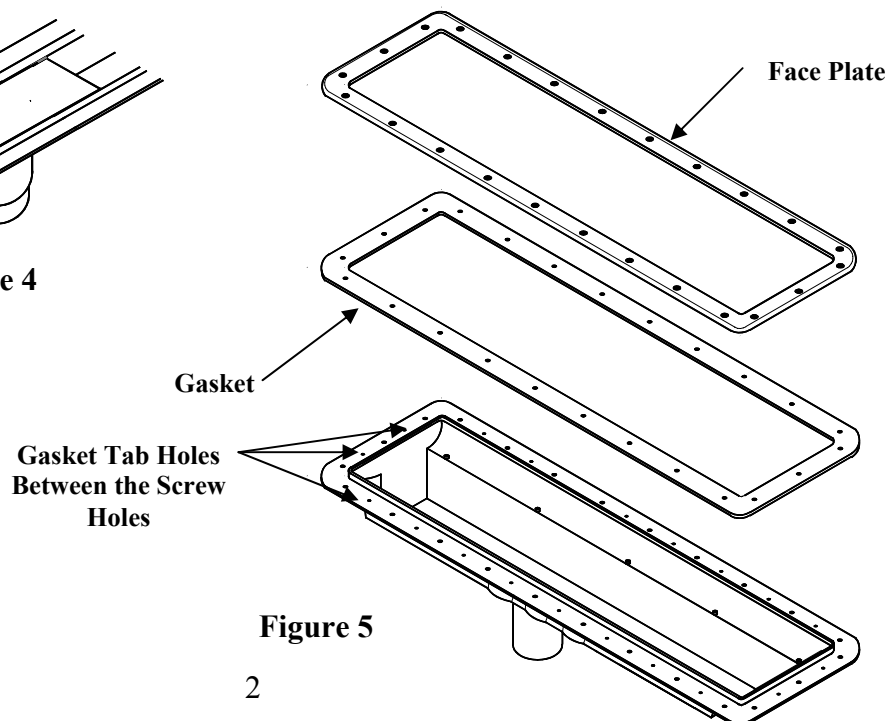

Figure 5

Install the Channel Drain Face Plate & Secure

1. Once the liner is properly positioned in the pool and all the required suction vacuums are in place; the liner should be stretched into place.
2. Use **CAUTION** when installing and securing the face plate.
3. Starting at either end of the Channel Drain, place the face plate into position and apply slight pressure to seat the face plate around the inner lip (see Figure 6).
4. Once the face plate is firmly in place and seated properly, use an awl to punch a hole through the vinyl sheet at each screw hole.
5. Install **ONLY** the supplied screws using hand tools only. (*using any other screw or power tools could damage or break through the bottom of the Channel Drain backing*).
6. Install the screws following the tightening sequence provided in figure 7.
7. **DO NOT** fully tighten any screw until all the screws around the entire Channel Drain have been installed. ***TIGHTENING THE SCREWS TO THE POINT WHERE THE SCREW HEADS ARE SEATED IN THE COUNTERSINK OF THE FACE PLATE, PRIOR TO STARTING ALL OF THE SCREWS, WILL MAKE IT DIFFICULT TO START THE REMAINING SCREWS.***
8. When finally drawing down all the screws tight, follow the tightening sequence provided in Figure 7. ***DO NOT USE POWERTOOLS TO TIGHTEN THE SCREWS***
9. Once the screws in the face plate are all tightened, carefully using a razor knife-cut the liner between the face plate and the inner lip of the Channel Drain and remove the liner piece.
10. Install the cover plate to the Channel Drain using the Torx Safety Screws

