

# Living Waters System Installation Instructions

The Living Waters System comes with six fountainheads, for use in water depths from 6 to 18 inches, and one 1½" cross-plumbed water feature specific rotating valve. The layout of the six fountainheads is up to the imagination of the installer and is therefore not discussed in this document.

## PRE-PLASTER INSTRUCTIONS

1. Determine the location of each Living Waters fountainhead and dig the necessary trenches to accommodate the 1½" feed lines to the fountainheads. Dig a **vertical** hole at least 25" to 26" deeper than the trench to accommodate the 24" long lower fitting. (See Figure 1) **NOTE:** Do not place a fountainhead any closer than 6" to the edge of a bench or shelf.
2. The trenches must be deep enough to allow the Tee in the fountainhead assembly to be at least 4" below the finished concrete (gunite or shotcrete) surface.
3. The Living Waters fountainheads are designed to be plumbed in pairs. (Each port of the valve should fire two heads). A brass gate valve should be plumbed into the header prior to the rotating valve to allow for height adjustments to the fountain heads (See "Header Detail" Section below).
4. After the fountainhead has been glued in place, fill the dirt in around the lower fitting and feed lines making sure the unit remains plumb.
5. Just before installing the finished surface to the pool, cut the A&A risers flush with the concrete surface. This should be done at the same time the cleaning heads are set.
6. Using the same color floor fitting housing as used in the floor cleaning system, glue the fittings in place. (See Figure 2)
7. **Do Not** remove the plaster shield from the floor fitting housing until the finished surface has been applied to the pool. The fountainhead tube must be sized and cut after the pool is filled.

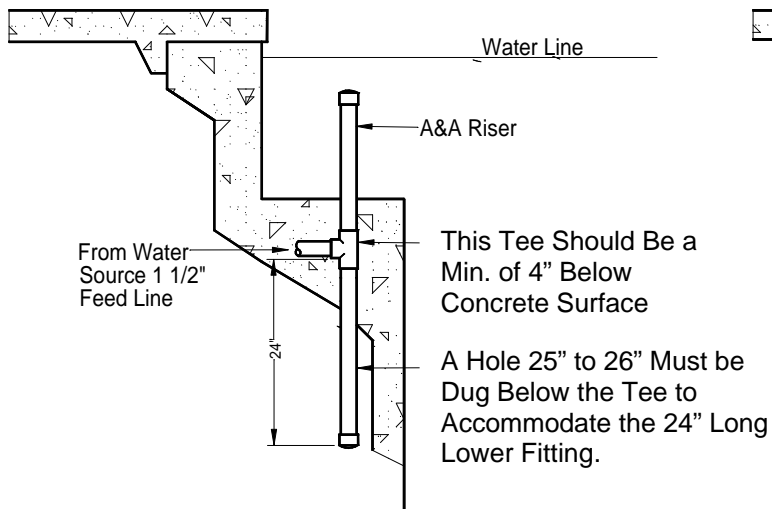

Figure 1

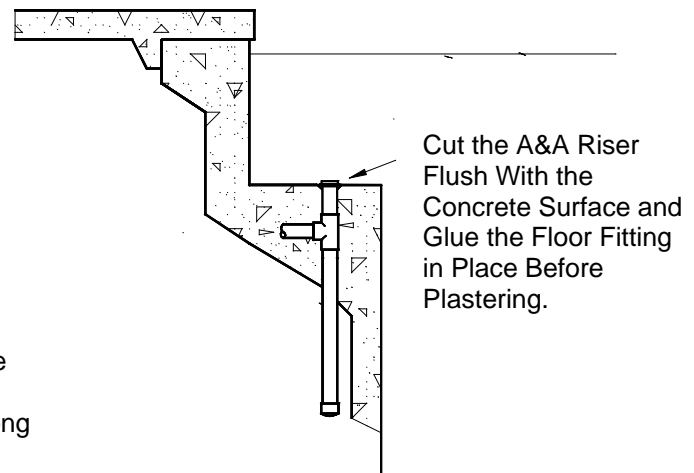

Figure 2

## POST-PLASTER INSTRUCTIONS

1. Remove the plaster shield from the floor fitting housing. After the pool is filled, measure the exact depth of the water at the fountainhead location.
2. With an A&A Installation tool (with 3 prongs), remove the fountainhead housing from the floor fitting housing.
3. Remove the fountainhead nozzle (see Figure 2) from the fountainhead tube and cut the tube to the length required for the nozzle to rise within 2" of the pool water surface. Cut the plain end of the tube opposite the end with the inlet fitting.
4. **IMPORTANT**, before gluing the nozzle to the end of the sized fountainhead tube, insert the cut end of the tube up through the bottom of the fountainhead housing **then** glue the nozzle in place using clear PVC to PVC cement. (See Figure 4)
5. Reinstall the assembly by installing the collar back into the floor fitting housing.

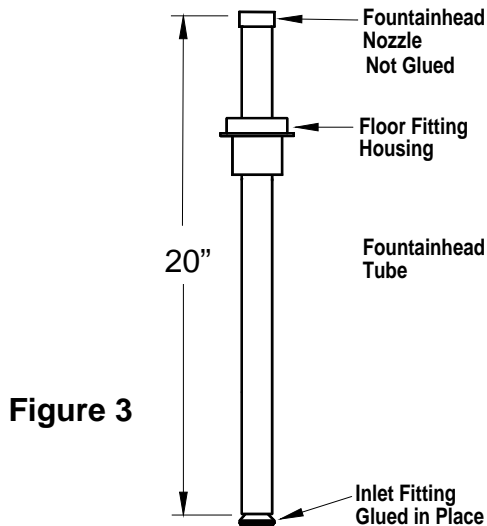

Figure 3

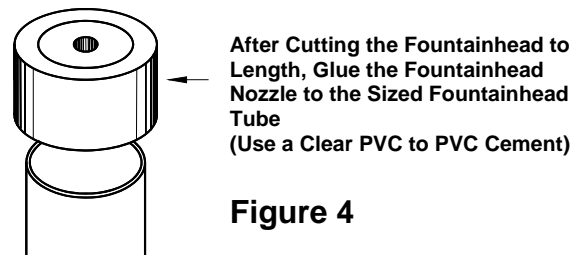

Figure 4

## How to Determine Fountain Base Size

The following drawing and chart are provided so that you can determine how close you may install the Living Waters Fountain to a pool edge. The higher the desired peak of the fountain, the further the fountainhead must be installed from the pool edge.

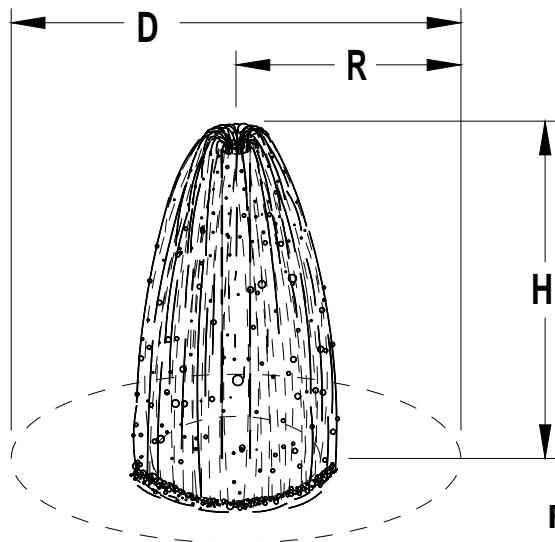

Figure 5

Height	Radius	Diameter
2'- 0"	3'- 0"	6'- 0"
2'- 6"	3'- 9"	7'- 6"
3'- 0"	4'- 6"	9'- 0"
3'- 6"	5'- 3"	10'- 6"
4'- 0"	6'- 0"	12'- 0"

### To Use the Above Chart:

1. Determine the desired fountain height you are trying to accomplish.
2. Find the desired height in the above chart and use the provided radius to determine the approximate minimum distance the fountainhead must be installed from the pool edge. Any closer and the water from the fountain will fall on the deck of the pool.
3. The estimated diameter of the entire fountain base is provided.
4. Example: If you desire a fountain height of 2'-0" the fountainhead must be at least 3 feet from the pool's edge and the diameter of the fountain base will be 6'-0".
5. Minimum water depth is 6 inches maximum water depth is 18 inches.
6. You cannot place a fountainhead any closer than 6 inches to the edge of a bench or shelf.
7. Approximately 12 - 15 GPM is required for each fountainhead.
8. Living Waters Fountains must be installed parallel to the water line in areas such as bench shelves, extended steps (other than the 1<sup>st</sup> step), spa floor, etc. **Do Not** install them in the pool floor, radii or side walls.
9. The fountain housing **must be** plumbed and set at a perfect 90° angle so that the fountain comes up in a perfectly vertical column.

**Note:** In the above drawing, the radius and diameter boundaries appear to be twice as large as the fountain column of water. The additional area is required to contain any intermittent sprays and splashes.

# Living Waters Header Details

## Living Waters System with In-Floor Cleaning

1. **Note:** When installing a Living Waters System that uses a circulation pump that also powers the in-floor system, the in-floor will not function during Dancing Waters use.
2. It is necessary for a gate valve to be installed between the 3-way valve and the rotating valve, so that fountain water heights may be adjusted. (See Figure 6)
3. **Do Not** use a 2-way or 3-way valve in place of the gate valve to feed the fountains. The gate valve is required to provide precise fountain height adjustments.

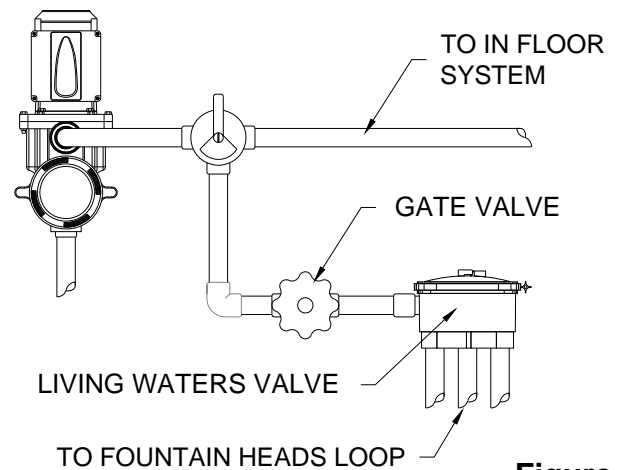

Figure 6

## Living Waters System With a Separate Booster Pump

1. If a separate booster pump is used to run the Living Waters System it is important to size the booster pump to accommodate only two Dancing Waters fountains (approximately 30 GPM).
2. If excessive flow is generated by the booster pump a wall return will be required to accommodate the extra flow.
3. It is necessary for a gate valve to be installed between the booster pump and the rotating valve to provide adjustment of the fountain height. (See Figure 7)

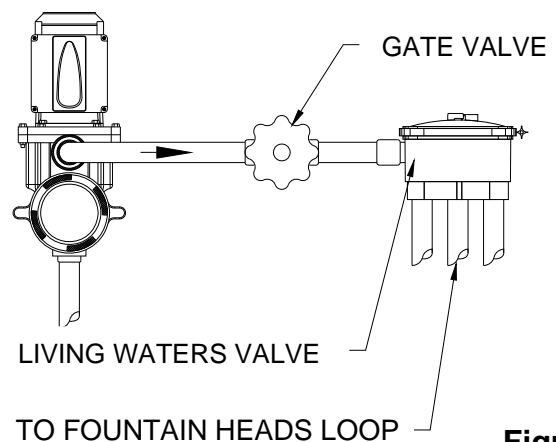

Figure 7

## Looping of each set of Living Waters Fountain Heads

1. It is essential that each set of Living Waters Fountain Heads be looped to ensure equivalent water flow is delivered to each head (See Figure 8).

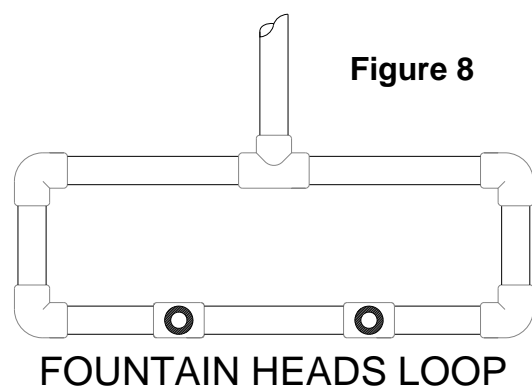

Figure 8